



# AC-23 Accelerometer

## User Manual

<b>Company:</b>	<b>GeoSIG Ltd</b> Ahornweg 5A, 5504 Othmarsingen, Switzerland, Tel: +41 44 810 21 50, Fax: +41 44 810 23 50, E-mail: info@geosig.com
<b>Author:</b>	Serge Rudaz
<b>Checked:</b>	Lukas Gätzi
<b>Approved:</b>	Johannes Grob
<b>Distribution:</b>	GeoSIG Ltd (1), Customer on request

## DOCUMENT REVISION

---

Date	Version	Author	Checked	Description
15.04.95	0	SR	JP	Created
11.04.00	1	JG	GCO	Format/Font changes
05.07.01	2	SR	JG	Update pictures and connector description for new 12 poles version. Added principle of operation.
30.05.2003	3	LG	JG	Changes for new housing
06.06.2003	4	LG	JG	Corrected axis polarity for new housing. Movement in axis-direction gives positive response.
05.12.2003	5	SR	JG	Updated
21.04.2004	5	JG	JG	Reformatted
05.05.2006	6	SR	JG	Adapted to new DH housing
12.12.2007	7	TB	TB	Adapted to new sensor housing File name and title change
13.12.2007	8	TB	TB	Detailed sensor full scale & offset adjustment
18.03.2011	8	THL	TAB	Board connector pinning added

---

# TABLE OF CONTENT

---

- 1 ELECTRICAL CONNECTION ..... 4**
  - 1.1 MAIN CONNECTOR PIN ASSIGNMENT ..... 4
  - 1.2 MATING CONNECTOR ..... 4
- 2 MOUNTING..... 5**
- 3 THEORY OF OPERATION..... 6**
  - 3.1 INTRODUCTION..... 6
  - 3.2 PRINCIPLE ..... 6
  - 3.3 BASIC SPECIFICATIONS..... 7
- 4 ELECTRICAL CONFIGURATION ..... 8**
- 5 MOUNTING (DOWNHOLE SENSOR) ..... 9**
  - 5.1 BOREHOLE PREPARATION ..... 9
  - 5.2 INCLINOMETER TUBE INSTALLATION..... 10
  - 5.3 SENSOR INSTALLATION ..... 11
  - 5.4 INCLINOMETER CASING ASSEMBLY ..... 12
  - 5.5 AXIS ORIENTATION ..... 14
- 6 INSTALLATION VERIFICATION..... 14**

The sensor housing provides no protection against explosive atmosphere. It must not be directly operated in area where explosive gases are present.

## 1 Electrical Connection

### 1.1 Main Connector Pin Assignment

All the AC-2X accelerometers use the same 12 pins male metallic style connector as the AC-43 and AC-63. The connector pins standard assignments are as follows:

Pin	SIGNAL	Comment	Color
1	OUTPUT X (+)	0 V ± 5 V voltage output, 47 Ω output impedance	White
2	OUTPUT X (-)	0 V ± 5 V voltage output inverted, 47 Ω output impedance	Brown
3	OUTPUT Y (+)	0 V ± 5 V voltage output, 47 Ω output impedance	Green
4	OUTPUT Y (-)	0 V ± 5 V voltage output inverted, 47 Ω output impedance	Yellow
5	OUTPUT Z (+)	0 V ± 5 V voltage output, 47 Ω output impedance	Grey
6	OUTPUT Z (-)	0 V ± 5 V voltage output inverted, 47 Ω output impedance	Pink
7	TEST INPUT	Test input, output will result in a sensor step response	Blue
8	GROUND	Ground, not connected to mechanical ground	Red
9	+12 VDC power	Power input, +10 to +15 VDC range, 50 mA @ +12 VDC	Black
10	GROUND	Ground, not connected to mechanical ground	Violet
11	AUX	Auxiliary input (reserved)	-
12	GROUND	Ground, not connected to mechanical ground	-

Table 1 AC-2X Connector Pin Assignment

In case no connector is mounted at the cable end (like usually for down-hole version), the color code is given in the above table.

### 1.2 Mating connector

GeoSIG	P/N #J_CIR.012.002.F
CONINVERS	P/N RC 12 S 1 N 12L 300
Binder Serie 623	P/N 99 4622 00 12

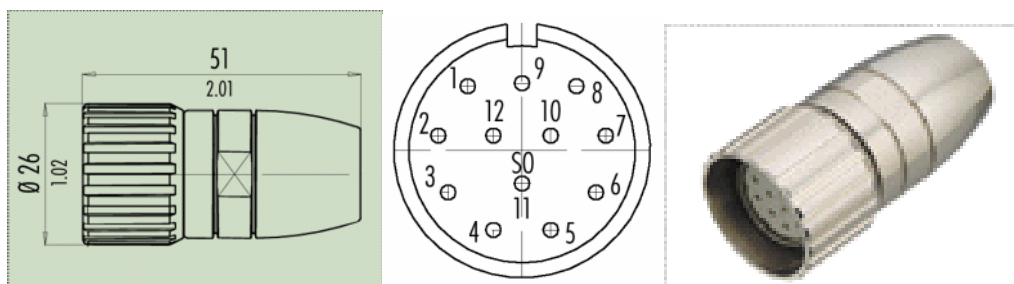
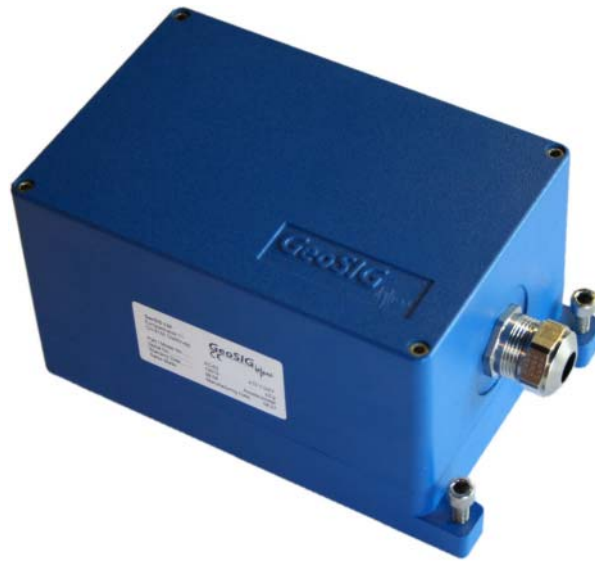

Figure 1, Mating connector

Cable gland nut has to be determined as per cable external diameter and must be separately ordered. It has also to provide the cable shield connection to connector case.

## 2 Mounting



**Figure 2, AC-2X housing**

Small size and single bolt attachment allow the AC-2X to be easily installed saving installation time. Leveling is accomplished via three point leveling screws.

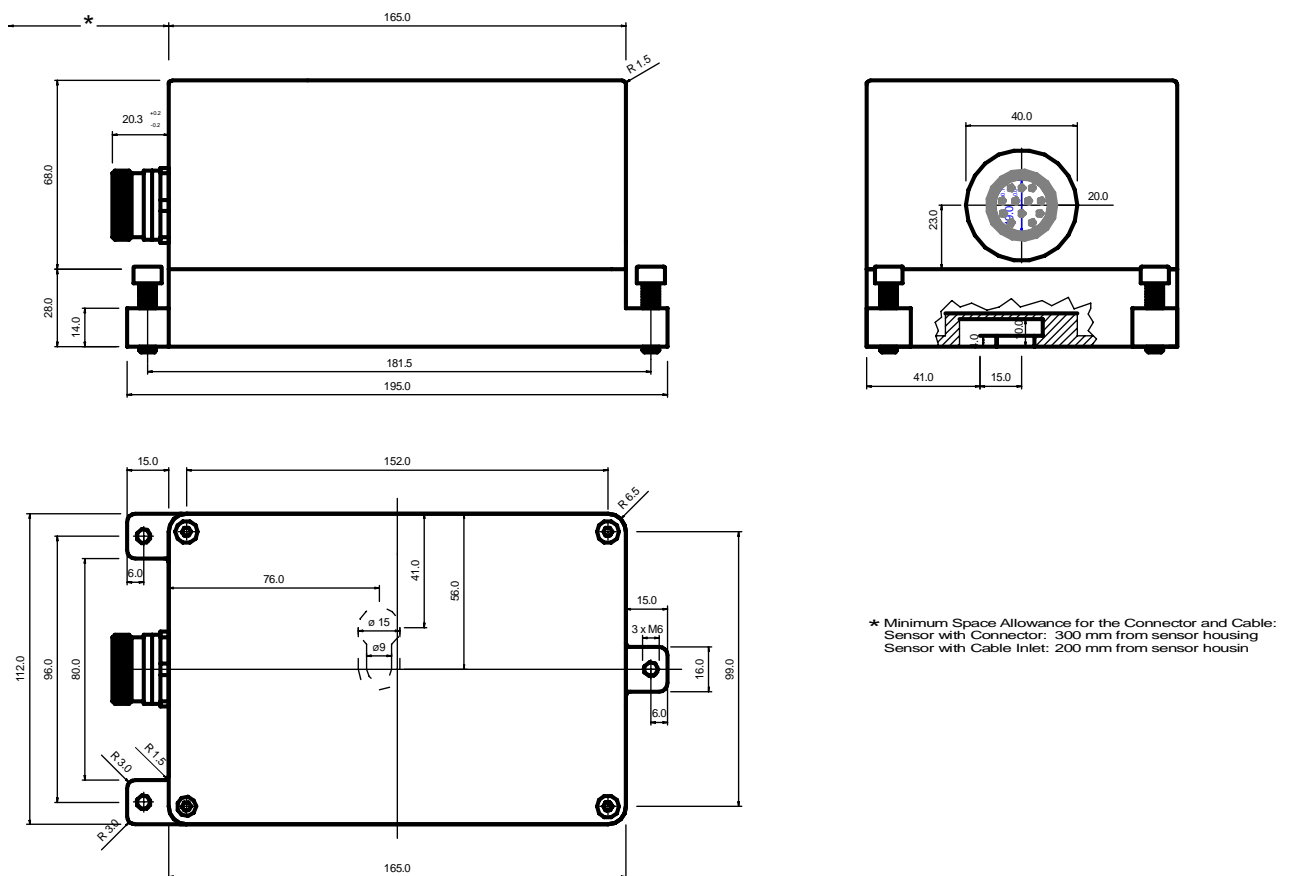

**Figure 3, Sensor housing dimensions**

The accelerometers must be firmly mounted to a surface and leveled, as the application requires. Check to be sure that the accelerometer is aligned to produce the desired output signals. Acceleration in the direction indicated on the case will produce a positive output signal. The orientation definitions as shipped are: **X = North, Y = West and Z = UP.**

The accelerometer has single-bolt, 3-feet-levelling mechanism. The surface should have a scribed north/south orientation line accurately surveyed from reliable markers. The X-axis of the sensor has to be pointed to East or to any other main direction of the structure to monitor. One M8 expanding nut rock anchor must be used for the sensor fixation.

### 3 Theory of operation

#### 3.1 Introduction

The **AC-23** sensor package is a triaxial accelerometer designed for free field and industrial applications regarding STRONG-MOTION earthquake survey, monitoring and research. This sensor is well suited for applications where a high sensitivity is required.

The AC-23 sensor can be optionally installed into a rugged protective housing. This optional protective housing is in stainless steel for optimal environmental resistance. As option, the protective housing could be executed with an IP68 grade for Free field location where the possibility exists of housing submersion.

The sensor could be installed on floor or wall with a modification of the axis organization. With the help of the **TEST LINE**, the complete sensor can be very easily completely tested. Full scale can be field selected by the user with jumpers.

#### 3.2 Principle

The accelerometer is based on a geophone mass-spring system with electronic correction. This type of sensors gives a very good stability in temperature and aging because of the very simple principle. It uses a damped mass spring oscillator called "Geophone" to convert seismic movement into electrical value proportional to the velocity. In a graphic with constant acceleration, the geophone response will present a maximum at the frequency called "Natural Frequency" which is the resonant frequency of the mass-spring oscillator. Above and below this point, the response will decay with one pole slope ( $\pm 20$  dB / decade). The corrector will over-damp the geophone by applying a voltage with opposite polarity over the geophone and the output response will be flat and proportional to the acceleration in this frequency band.

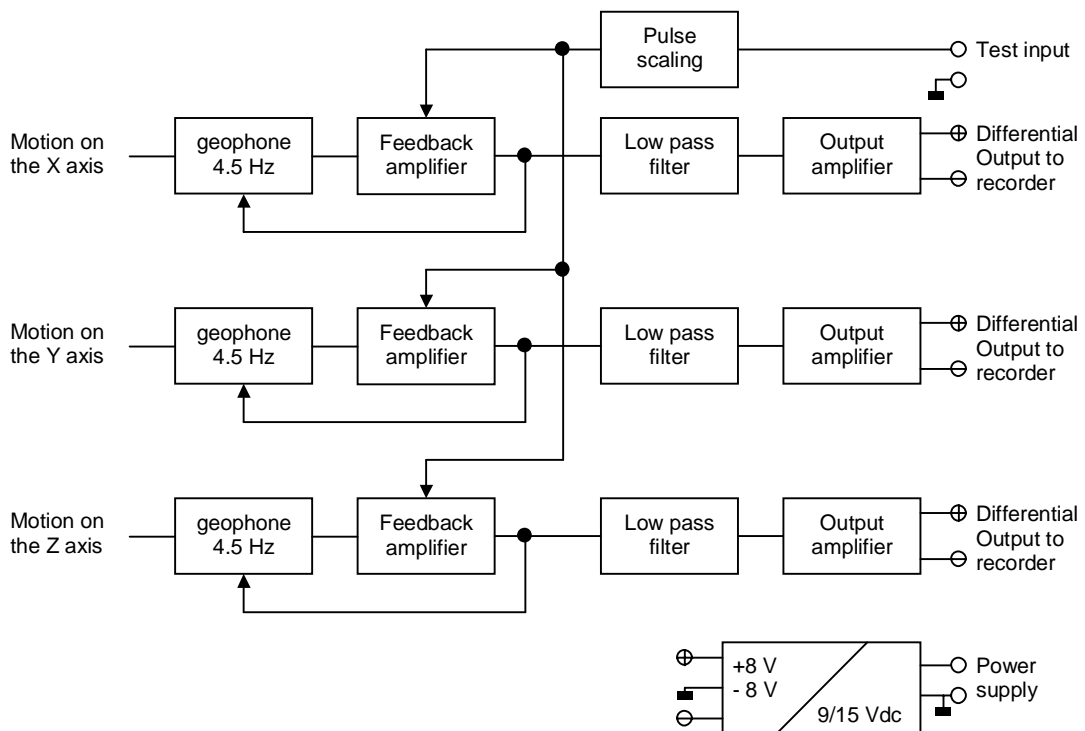

Note : all inputs, outputs & power supply entry are surge protected.

Figure 4 AC-23 Sensor block diagram

The geophone is connected in a resistor bridge, driven by a feedback amplifier, which applies the amplified bridge differential signal in opposite polarity. The bridge is balanced during calibration. The test-line shifts the voltage at one side of the bridge, which produces a current flow in the geophone.

This current flowing in the Geophone will move the seismic mass. The movement of the mass generates a voltage across the Geophone, which is detected by the differential amplifier and induces an output signal.

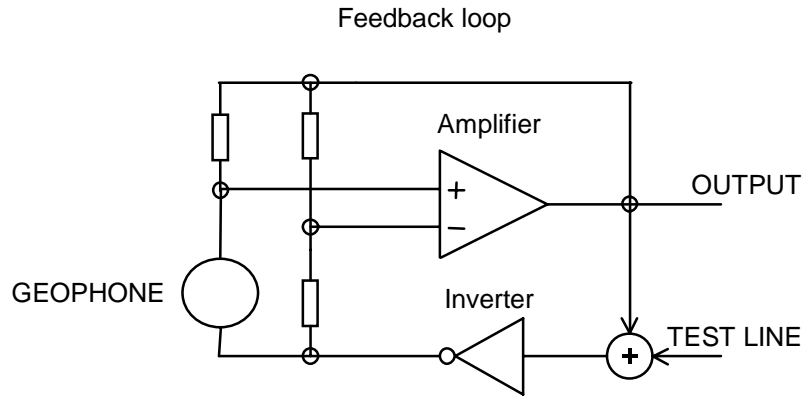

**Figure 5 TEST INPUT configuration**

### 3.3 Basic specifications

Detailed specifications	AC-23
Input range	Acceleration, $\pm 0.2$ , $\pm 0.5$ , $\pm 1.0$ g or $\pm 2.0$ g
Output range	0 $\pm$ 10 Volt differential output OR 0 $\pm$ 5 Volt differential output OR 2.5 $\pm$ 2.5 Volt single-ended output OR 0 – 20 mA Current-loop (OPTION)
Frequency range	from 0.1 Hz to 50 Hz (Optional from 0.2 Hz)
Protections	All connectors pins protected by Transzorb diodes and VDR
Power supply	10 – 15 VDC
Current drain	Typical 30 mA @ 12 VDC

#### 4 Electrical configuration

The fullscale can be adjusted without gain re-calibration by means of jumpers with fixed 0.1% precise amplifiers.

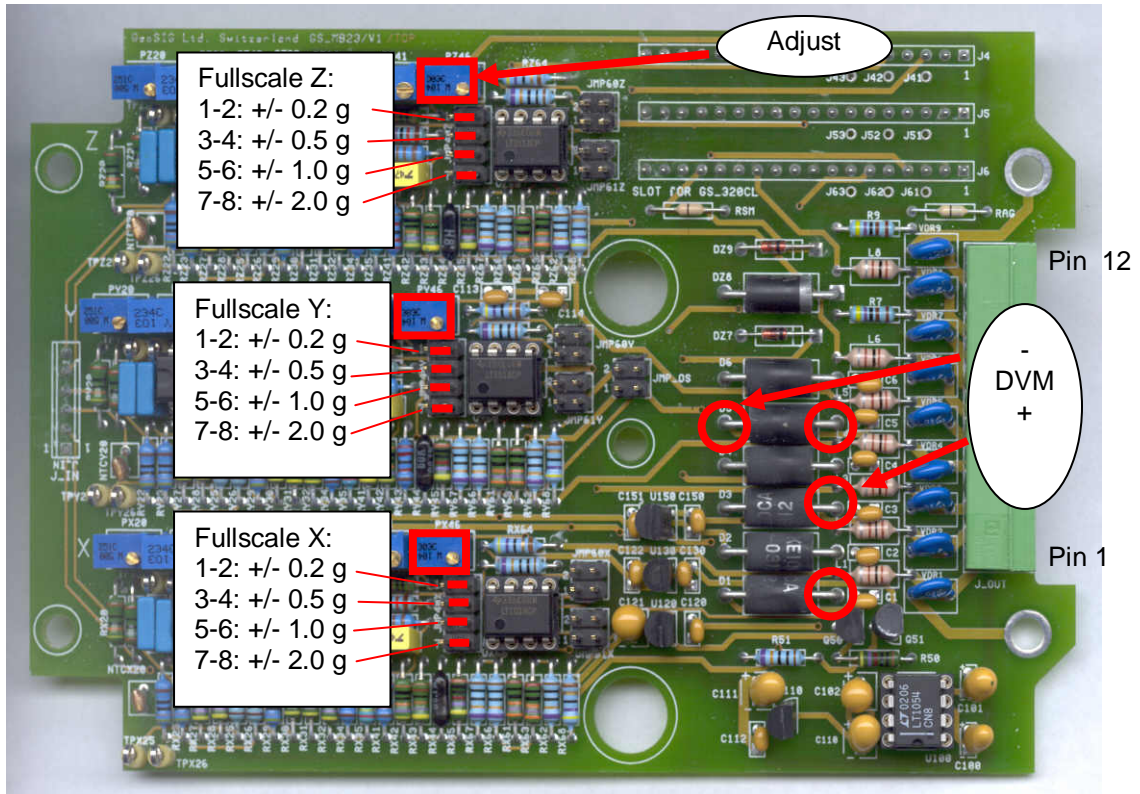



Figure 6, Fullscale setting

After the new full scale has been selected, the offset potentiometers  need to be re-adjusted to remove any offset at output.

Connect a Digital Voltmeter (DVM) as shown on the above figure and adjust the offset potentiometers so that the DVM readings stay within the ranges indicated in the following table, according to the sensor output range given in Section 3.3:

Sensor Label*	Sensor Output Range	DVM Reading
±10 Volts	0 ± 10 Volt differential output	0.00 ±0.05 V
±5 Volts	0 ± 5 Volt differential output	0.00 ±0.05 V
2.5 ±2.5 Volts	2.5 ± 2.5 Volt single-ended output	2.50 ±0.02 V
10 ±10 mA	0 - 20 mA Current-loop (OPTION)	2.50 ±0.02 V

\*:The output range is written on the sensor label.



## 5 Mounting (downhole sensor)

The sensor must be installed in a 3-inch inclinometer tube. At least a 100 mm borehole must be drilled. Depending on the soil condition, it could be required to drill a higher dimension hole and to implement a 120 mm PVC casing to insure a free path when the inclinometer tube is inserted in the borehole.



### 5.1 Borehole preparation

Note: Do not scale the drawing.

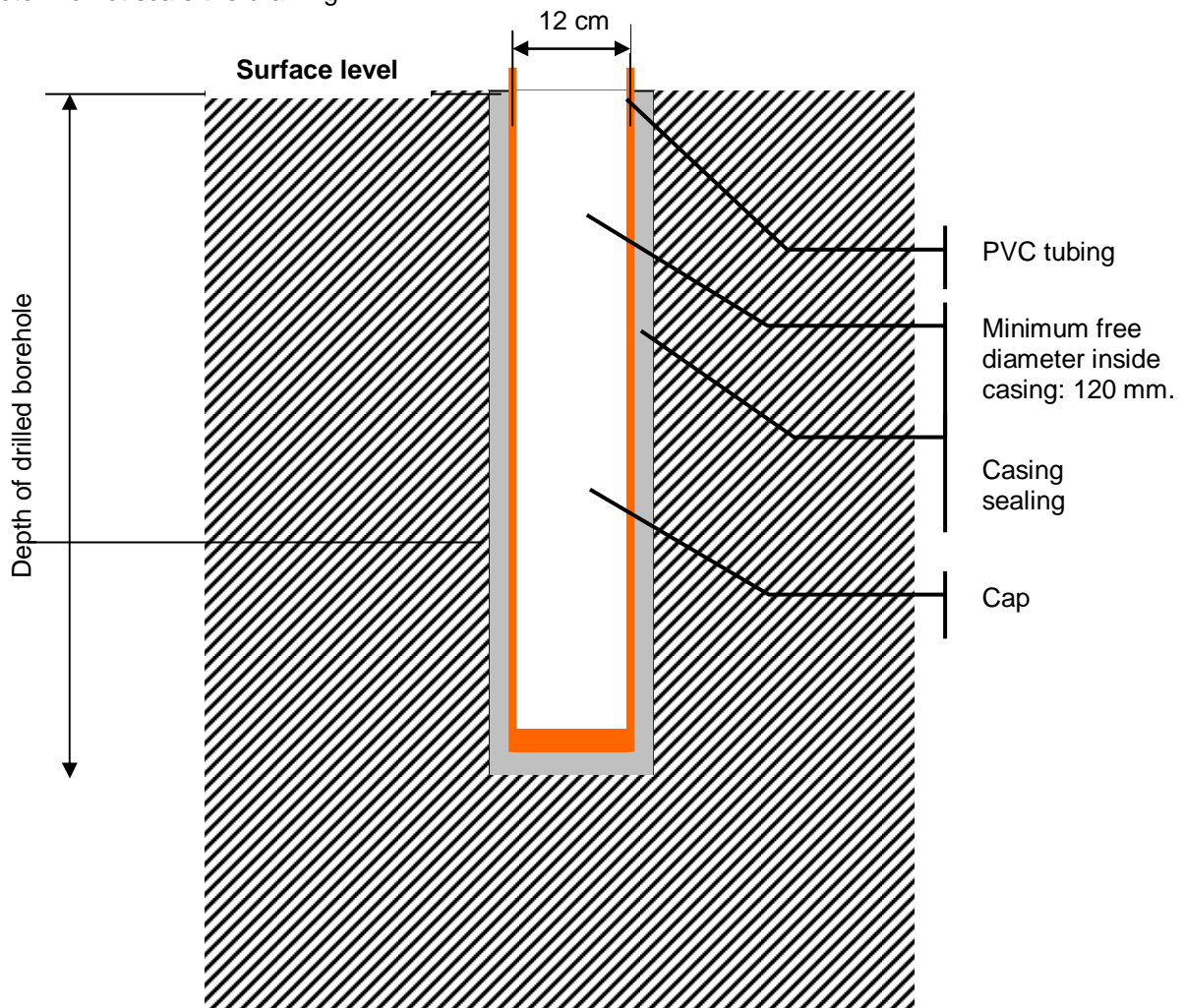

Do not allow concrete mix from casing sealing to enter the casing.

## 5.2 Inclinator tube installation

Note: Do not scale the drawing. The number of section is only an example.

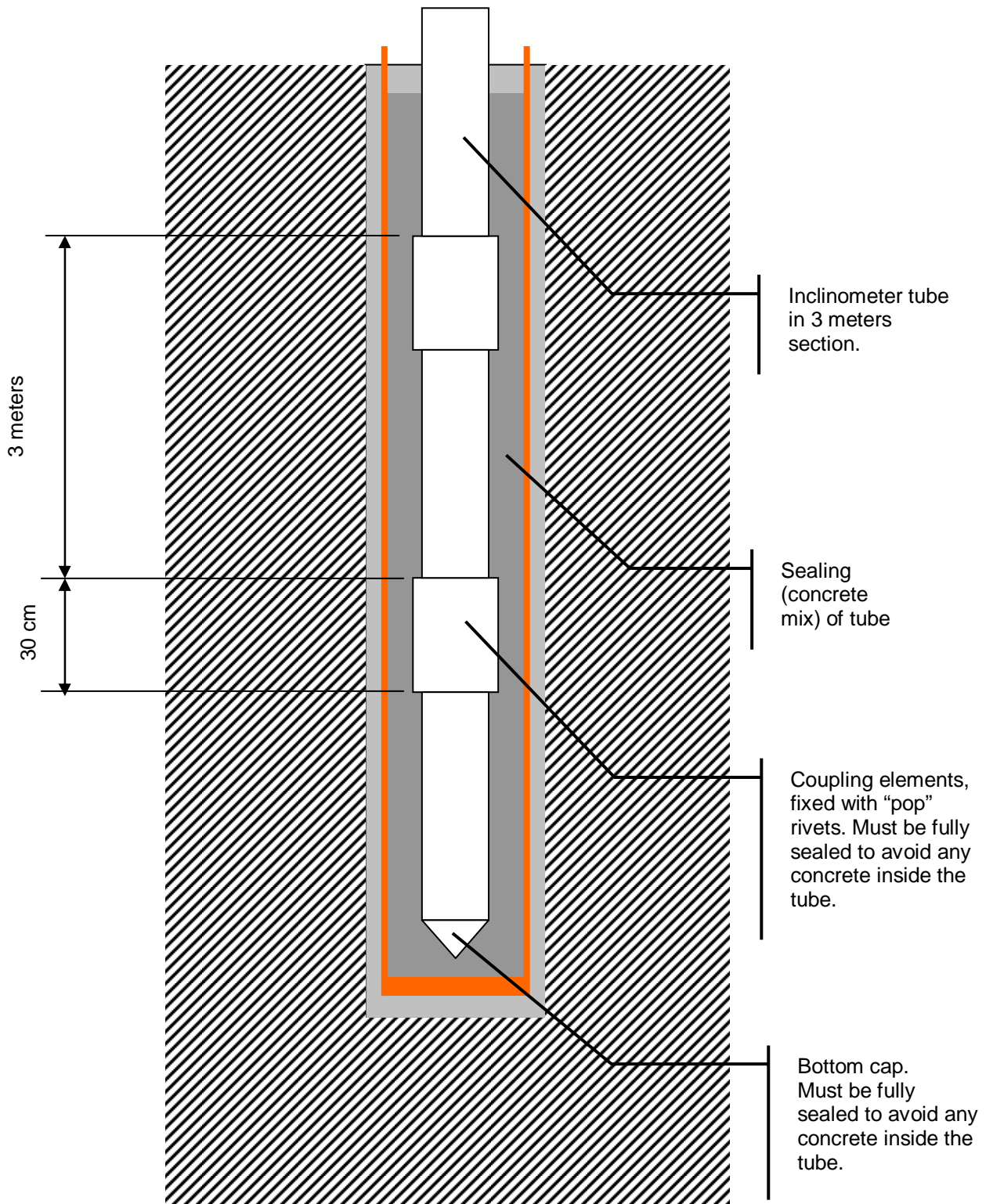

### 5.3 Sensor installation

Note: Do not scale the drawing. The number of section is only an example.

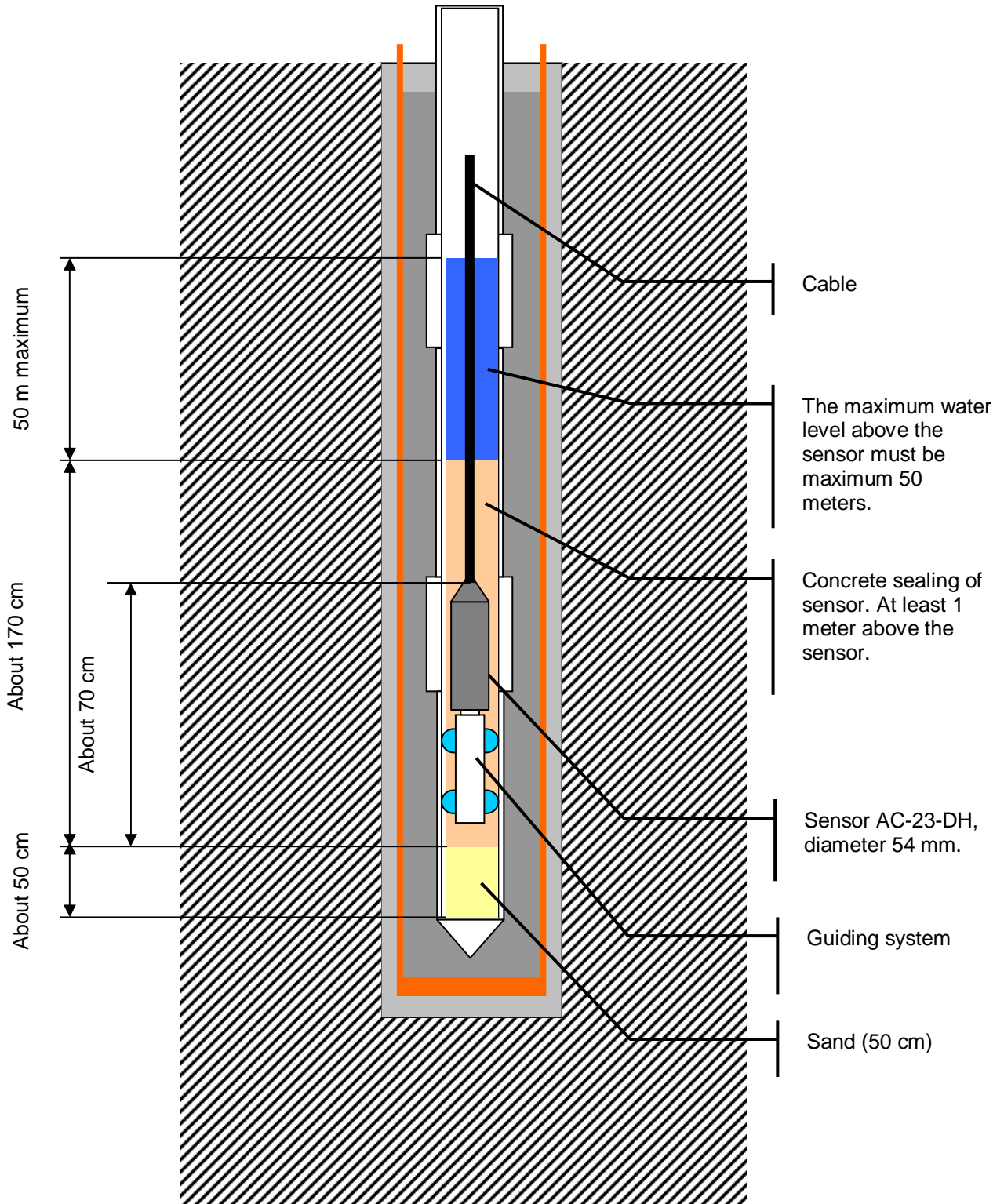

#### 5.4 Incliner casing assembly

The borehole must have a casing or the soil must insure that a free path for the inclinometer tube is warranted. It is recommended to insert the inclinometer tube as soon the borehole is ready.

The free path for the inclinometer tube should be 10 to 15 cm, 12 cm typically.

It could be required to insert some water in the casing to sustain the water pressure at the bottom of the borehole.

The inclinometer tube should be mounted with a maximum deviation of  $\pm 1^\circ / 3$  meters and with a maximum deviation from vertical at sensor location of  $\pm 3^\circ$ . The functional limit for the sensor is  $\pm 9^\circ$ .

The water level in the inclinometer tube should be maximum 50 meters, including fast elevation due to heavy rain.

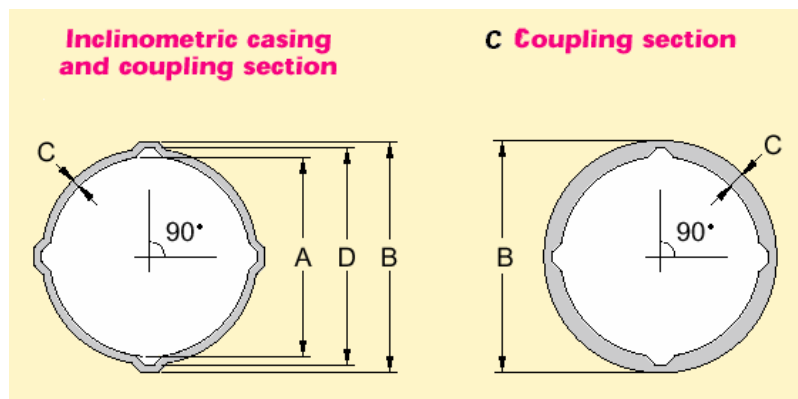

It is recommended to use the optional assembly kit that GeoSIG can provide (optional) with the inclinometer tube. It will insure a perfect sealing of the tube elements and would avoid concrete mix to enter the tube.

The dimensions of the inclinometer tube are:



INCLINOMETRIC CASING (3 m section)		COUPLING ELEMENT		
<b>A</b>	Inner diameter	76.1 mm	<b>A</b> Inner diameter	81.0 mm
<b>B</b>	Groove outer diameter	86.4 mm	<b>B</b> Outer diameter	92.0 mm
<b>C</b>	Thickness	2.2 $\pm$ 0.1 mm	<b>C</b> Thickness	2.2 mm
<b>D</b>	Groove inner diameter	82.0 mm	<b>D</b> Groove inner diameter	87.6 mm
	Length	3 meters	Length	300 mm
	Weight	1.4 Kg/m	Weight	0.5 kg
	Borehole diameter	> 120 mm		

The following elements will be inserted in the borehole.

Figure 7		Torpedo (the sensor and its cable)
Figure 8		Guiding system
Figure 9		Inclinometer tube

### 5.5 Axis orientation

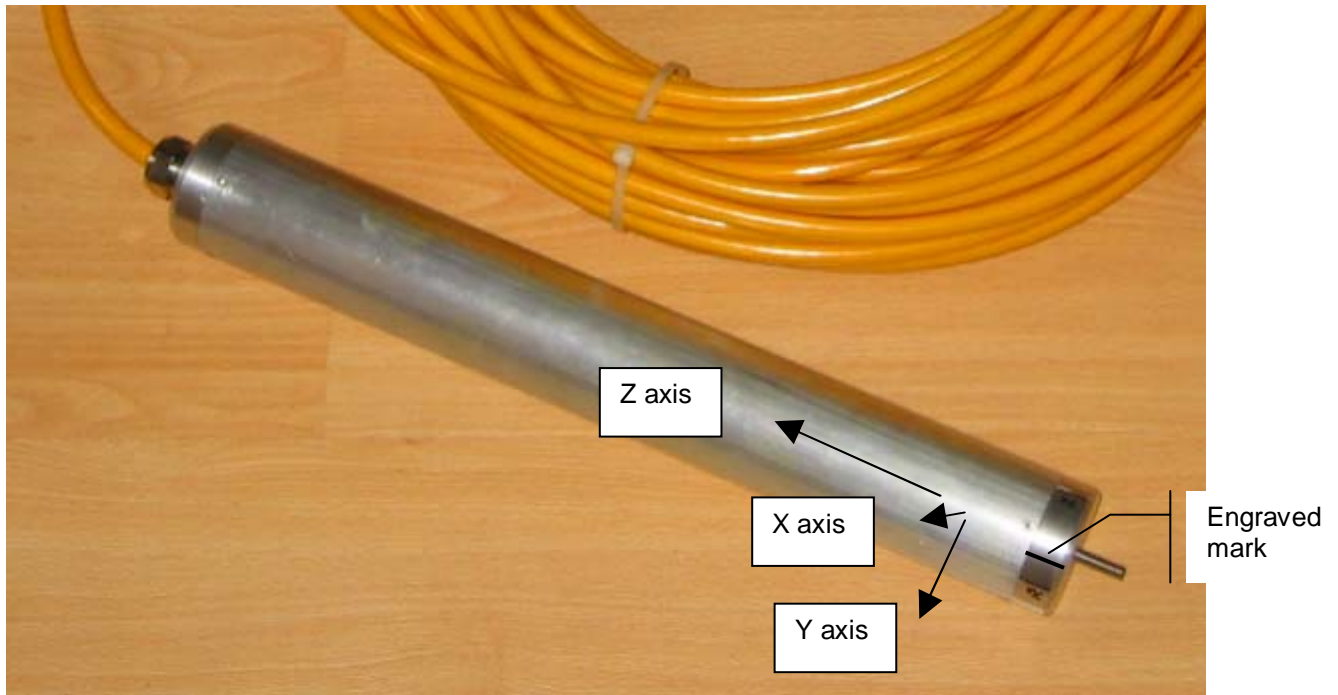
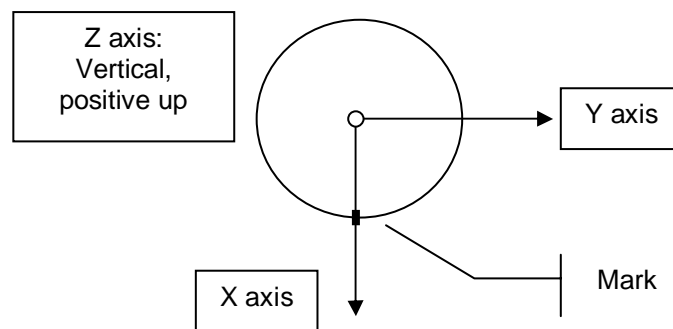

Figure 10, Down hole axis orientation

Before the sensor is inserted in the inclinometer tube, the guiding system must be mounted below it. The guiding system must be orientated before the insertion.

The engraved mark on bottom cover is showing the positive direction of X axis:



View for top:

## 6 INSTALLATION VERIFICATION

Please note that temperature compensation device is mounted for each axis inside the sensor and that the temperature in the sensor has to stabilize before accurate measurement can be done. Allow at least half an hour for temperature stabilization.